

FAULT FINDING CHART

GRAVITY or PUMPED SYSTEM	
FAULT	DIAGNOSIS
"Showering temperature is not hot enough"	<ul style="list-style-type: none"> • Ensure hot water supply is at least 60°C. • Make sure you have equal pressures. • Check for airlocks in pipework. • Ensure there are no inverted 'U's in any of the pipework runs.
"Water goes cold during shower"	<ul style="list-style-type: none"> • Insufficient hot water storage
"When shower is set at cold, the showering temperature is too hot"	<ul style="list-style-type: none"> • Hot and cold supply connections have been made in reverse - reconnect correctly
"Shower temperature is too hot (pumped shower)"	<ul style="list-style-type: none"> • Turn down the flow of hot water from the pump using the in-line isolator valve.

COMBI or OTHER HIGH PRESSURE SYSTEM	
FAULT	DIAGNOSIS
"Showering temperature is not hot enough"	<ul style="list-style-type: none"> • Incoming mains pressure exceeds 5 Bar - ensure you have fitted a pressure reducing valve in the mains supply pipe. • Ensure hot water supply is at least 60°C.
"Valve is very noisy when in use"	<ul style="list-style-type: none"> • Incoming mains pressure exceeds 5 Bar - ensure you have fitted a pressure reducing valve in the mains supply pipe immediately after stopcock to premises.
"The water goes cold whilst showering"	<ul style="list-style-type: none"> • Ensure the boiler is still firing. Adjust the boiler to the hottest output, not the best flow.
<p>NB Any product guarantees will be invalidated if the internal workings of the valve have been tampered with in anyway. Please call our HELPLINE if you are having any difficulties.</p>	

**If the Fault Finding chart does not remedy the problem, please contact the helpline immediately.
 Telephone 01282 428337.**

SINGLE LEVER CERAMIC DISC MANUAL SHOWER VALVE (exposed/concealed)

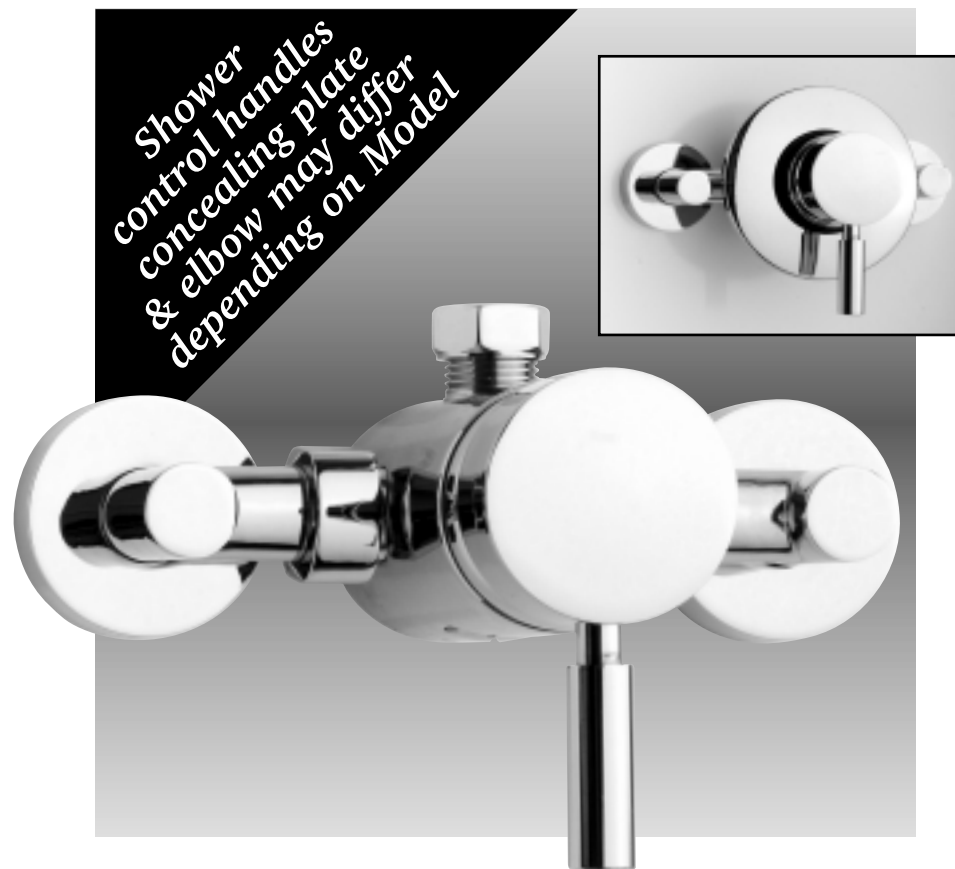

OWNER'S GUIDE

INTRODUCTION

This owner's guide shows you how to install, maintain and generally get the most from your manual shower valve.

WE RECOMMEND INSTALLATION BY A QUALIFIED PLUMBER ONLY

TECHNICAL DATA

This shower valve is suitable for use on all common types of plumbing systems including gravity, pumped, fully modulating combination boilers and high pressure unvented systems.

Minimum operating pressure 0.1 Bar

Maximum operating pressure 5 Bar

Important note: At static water pressures above 5 Bar, you must install a pressure reducing valve in the mains supply pipe set at 3 Bar static for optimum results.

As a guide to see if your water pressure is too high simply measure how many pints of water you get from your kitchen tap, with the cold side fully turned on. If you exceed 8 pints (or equivalent) in 30 seconds then you require a pressure reducing valve fitting to your incoming mains supply pipe, immediately after the stopcock to premises.

TEST DATA

These valves have been pressure tested to 15 Bar.

Before proceeding, please note:

1. The valve must be installed in compliance with local water authority byelaws and water supply byelaws.
2. Read all the instruction manual before proceeding.
3. Only begin the installation when you have all the necessary tools ready.
4. Please check that all the components are in the shower valve box.

AFTERCARE

When installing or using tools, extra care must be taken to avoid damaging the finish or the fitting. To maintain the appearance of this fitting, please ensure it is cleaned regularly using a clean soft damp cloth only. Abrasive cleaners or detergents must not be used as they may cause surface deterioration.

SINGLE LEVER CERAMIC DISC MANUAL SHOWER VALVE - Safety & Comfort

This shower valve is **NOT** thermostatically controlled and the outlet temperature depends on the position of the handle, hot and cold inlet temperatures and pressures. **IF THE COLD WATER SUPPLY FAILS FOR ANY REASON HOT WATER ONLY MAY BE DELIVERED.** Before using the shower **CHECK** that the temperature of the mixed water is comfortable.

YOUR SINGLE LEVER CERAMIC DISC MANUAL SHOWER VALVE KIT COMPRISES:

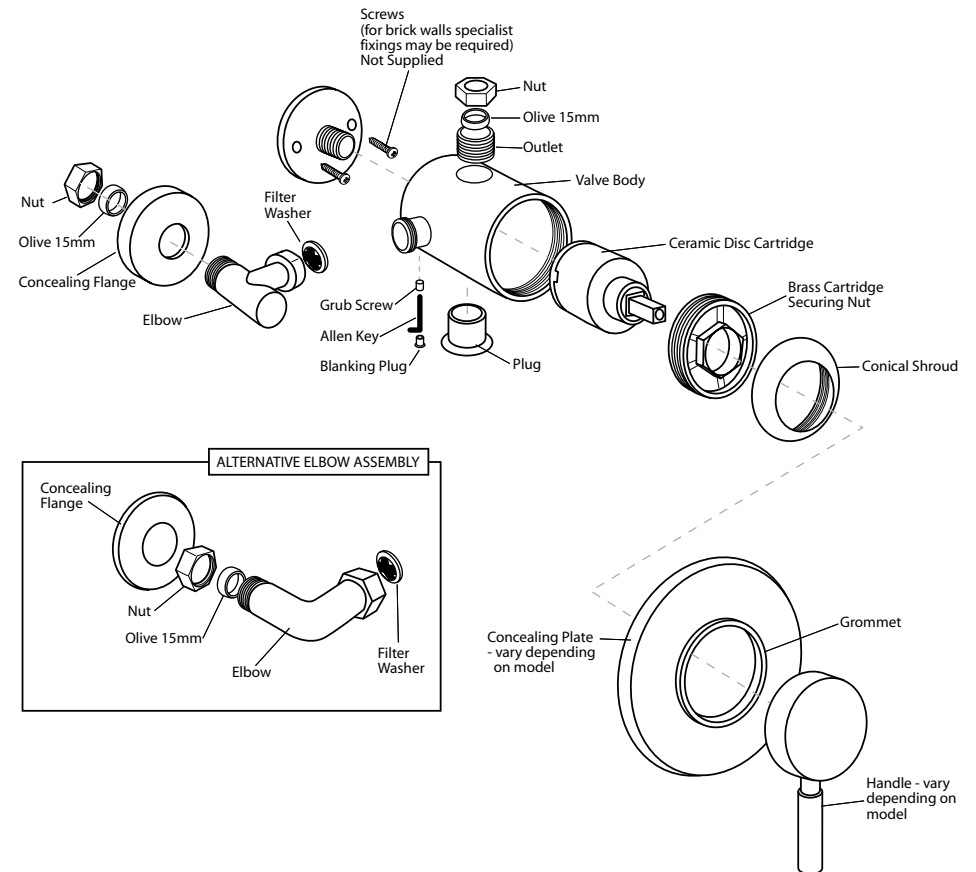

Note: Concealing flanges only used on exposed installations concealing plate only used on concealed installations.

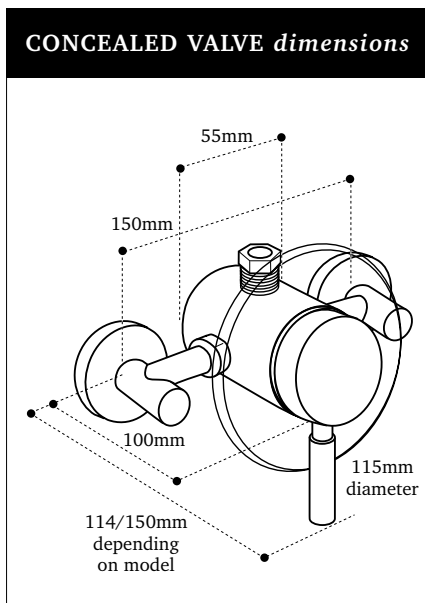
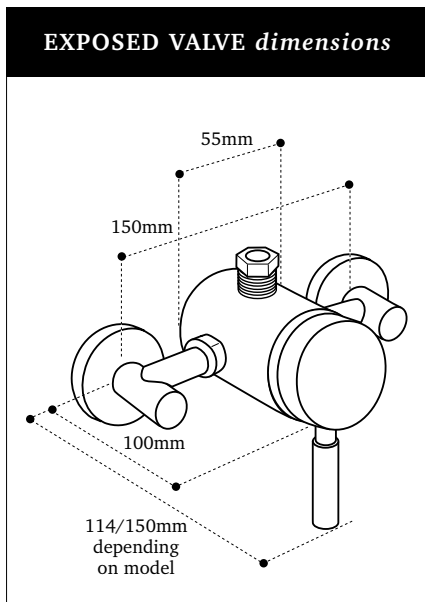

**PRE-INSTALLATION NOTES
for EXPOSED and CONCEALED
VALVES**

- Identify and check all the parts (**shower control handles & elbows concealing plate styles may differ depending on model**).
- When positioning the shower valve, ensure you have sufficient pressure for an acceptable shower.
- The hot water feed must **always** be connected to the left hand inlet of the shower valve as viewed from the front, with the shower outlet at the top.
- Both hot and cold supply feeds must have **accessible isolator valves** fitted in-line for servicing purposes (not supplied).
- Refer to plumbing diagrams for further installation guidelines.

**INSTALLATION NOTES
ON HOT WATER SYSTEMS**

PLUMBING DIAGRAMS

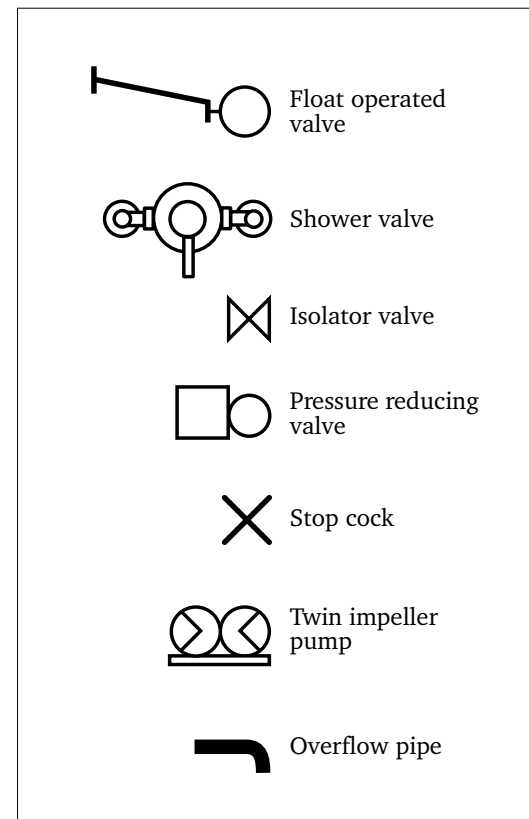

1. INSTALLATION INSTRUCTIONS

PLUMBING DIAGRAMS

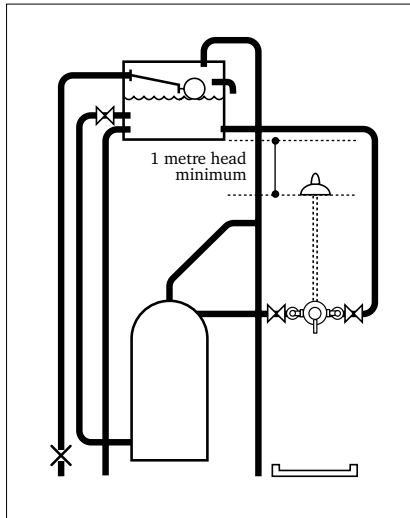
**Gravity Fed Showers**

The shower valve **must** be fed from a cold water storage tank and a hot water cylinder. The use of a Surrey or Essex flange connection to the hot water cylinder will ensure an independent supply of hot water to the valve; this action will stop air being drawn into the system.

NB Keep all pipework runs as short as possible for maximum shower performance.

NB Wherever possible 22mm pipework should be used.

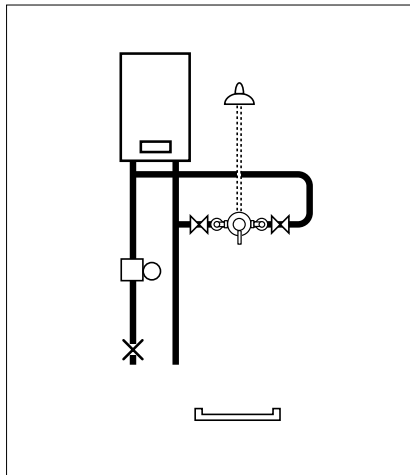
**Gas Heated/Combi-Boiler Showers**

The shower valve **must** be installed with a **modulating** type combi-boiler or multi-point gas heater. This system will produce a constant flow of water within the operating specifications of the appliance.

NB The outlet temperature of the system **must** be capable of supplying hot water **in excess of 60°C**.

A pressure reducing valve may be required to ensure that cold water pressures do not exceed 5 Bar static.

1. INSTALLATION INSTRUCTIONS

PLUMBING DIAGRAMS

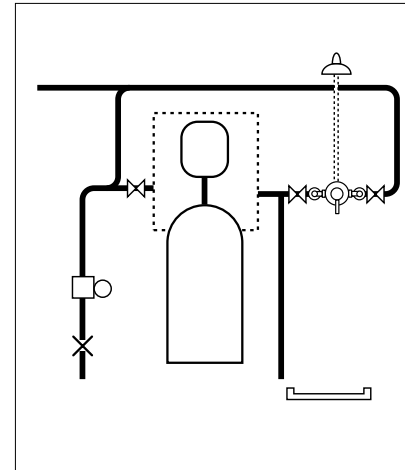
**Unvented Mains Pressure Showers**

The shower valve can be used on an unvented mains pressure system. This type of system **must** only be installed by **a competent person as per the requirement of Part G of Schedule 1 to the building regulations**.

For systems with no cold water take off after the heaters pressure reducing valve, an additional pressure reducing valve must be fitted, and set, at the same pressure as the heaters.

The water supply pressure to the shower valve must be between 1 and 4 Bar.

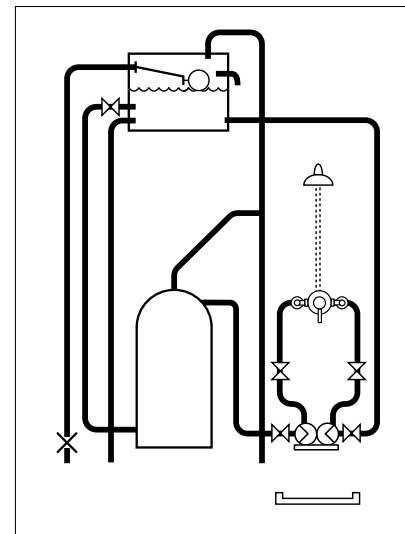
**Pumped Showers**

The shower valve can be used on a gravity fed pumped system. The use of a Surrey or Essex flange connection to the hot water cylinder will ensure an independent supply of hot water to the valve; this action will stop air being drawn into the system.

NB Please follow pump manufacturers' instructions relating to the siting and water feed details to the pump. Keep all pipework runs as short as possible for maximum shower performance.

NB Wherever possible 22mm pipework should be used.

INSTALLATION INSTRUCTIONS (continued)

INSTALLATION INSTRUCTIONS (continued)

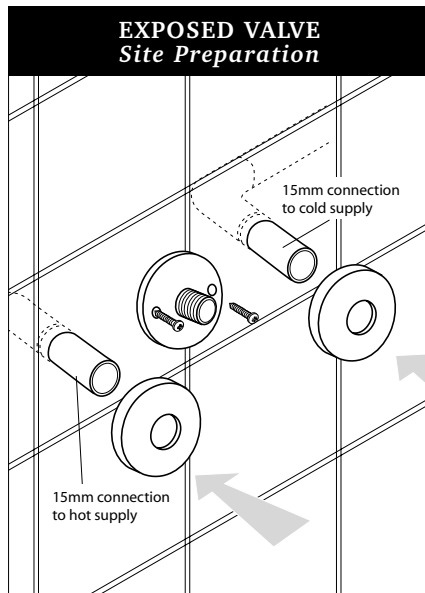

- Ensure hot and cold supply pipe feeds are positioned correctly ready to connect to the shower valve inlet elbows.
- If a rigid kit is being used, ensure the valve is positioned correctly to take the height of the vertical pipe.
- Position the wall peg and secure to the wall by means of two suitable screw fixings (not supplied).
- Both hot and cold supply feed must be **flushed through** before connection to the shower valve is made. Re Water Supply Byelaw 55.
- To create a waterseal, use a thin line of suitable sealant around the supply pipe feeds and the tiles.
- Fit the concealing flanges over the supply pipes - depending on model.

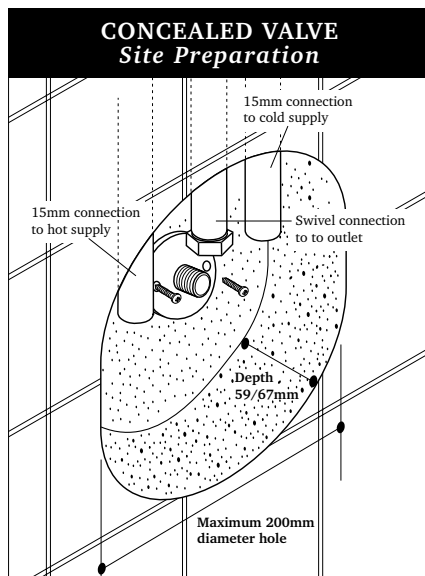

- Make a cavity in the wall to allow the hot and cold water connection to be made.
- Position the wall peg and secure to the wall by means of two suitable screw fixings (not supplied).
- Both hot and cold supply feed must be **flushed through** before connection to the shower valve is made. Re Water Supply Byelaw 55.

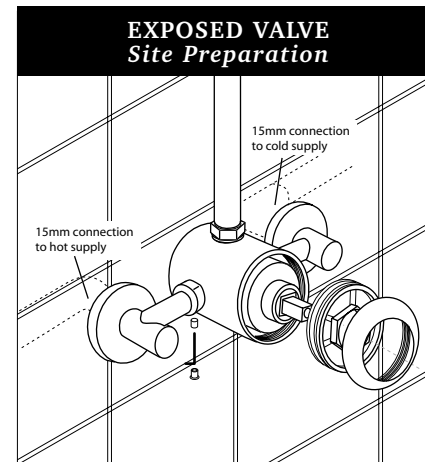

- Remove outlet using 12mm Allen Key (not supplied).
- Remove the plug using a suitable screw driver. NB Take care not to damage the finish
- Fit plug into outlet hole & tighten using a suitable screw driver. NB Take care not to damage the finish
- Fit outlet into plug hole & tighten with the 12mm Allen Key (not supplied).
- Check for water leaks.

- Connect the hot and cold water supply feeds to the shower valve, using swivel connector.
- Fit concealing flanges - depending on model.
- To create a waterseal, use a thin line of suitable sealant around edge of concealing flanges & the tiles - depending on model.
- Fit the shower valve to the wall peg and secure by tightening the grub screw using the Allen key provided. Fit blanking plug.
- Make connection to shower outlet.
- **Check for any leaks.**

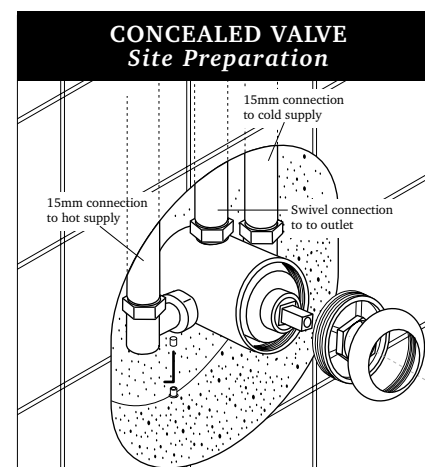
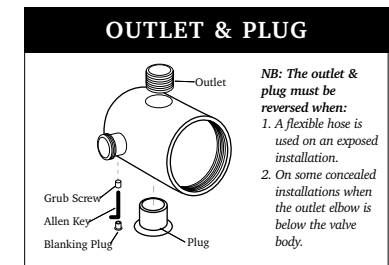

- Connect the hot and cold water supply feeds to the shower valve, using swivel connector.
 - Fit the shower valve to the wall peg and secure by tightening the grub screw using the Allen key provided.
 - Make connection to shower outlet.
 - Tile up/finish to the minimum recess size of diameter 100mm.
 - **Check for any leaks.**
- NB Please ensure that the area around the concealed valve is not filled in. Access must be left for servicing purposes.

INSTALLATION INSTRUCTIONS (continued)

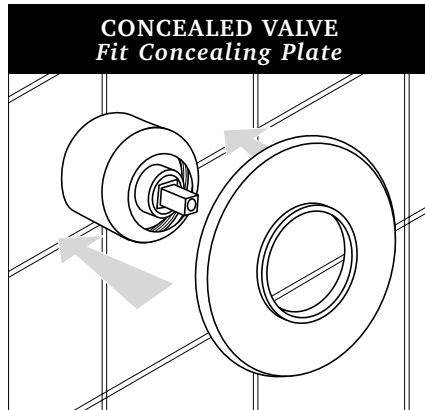

- Place grommet within the concealing plate centre and push plate into position.
NB. A mild soapy solution around the inside of the grommet will ease fitting.
- To create a waterseal, use a thin line of suitable sealant between the concealing plate and the tiles.

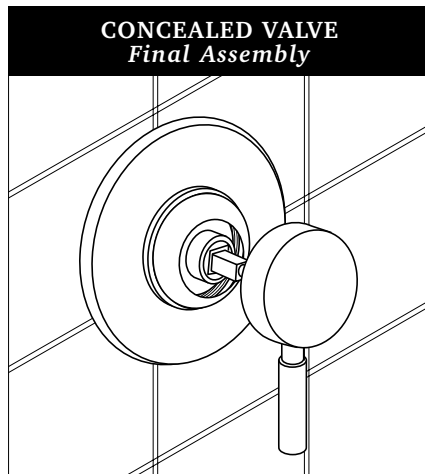

- Fit the shower control handle (shower control handle and concealing plate may vary depending on model).

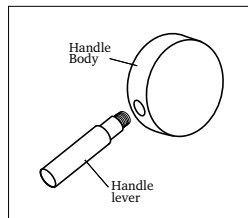
**HANDLE FIXING A**

- Unscrew handle lever from Handle Body, by hand.
- Locate Handle Body on valve, lever hole downwards.
- Insert Allen Key (provided) through Handle Body lever hole & tighten Grub Screw onto valve cartridge.
- Remove Allen Key
- By hand, replace handle level into Handle Body.

INSTALLATION INSTRUCTIONS (continued)

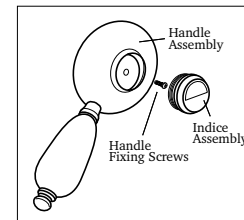
**HANDLE FIXING B**

- Unscrew and remove Indice Assembly.
- Locate Handle Assembly on valve with level downwards
- Using an appropriate screw driver tighten handle fixing screw through the handle into the valve cartridge.
- Replace Indice Assembly.

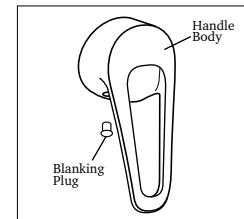
**HANDLE FIXING C**

- Remove Blanking Plug from handle.
- Locate Handle Body on valve, handle plug downwards.
- Insert Allen Key (provided) through plug hole & tighten grub screw onto valve cartridge.
- Remove Allen Key
- Replace Blanking Plug into Handle Body with red segment on left as viewed from front of valve.

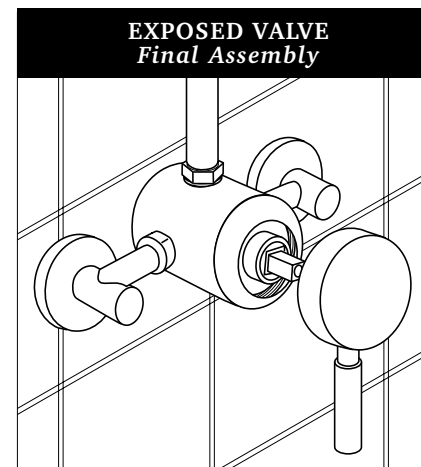

- Fit shower control handle (style may vary depending on model).
- Check function of the valve.

OPERATION ON SHOWER VALVE

1. To turn the shower **ON** pull the lever towards you.
2. To turn the shower **OFF** push the lever away from you.
3. Moving the lever left or right will alter the temperature from full HOT to the left through warm to full COLD on the right.