

SHOWER SEAT INSTALLATION INSTRUCTIONS

ISSUE: 1

CAUTION : MAXIMUM WEIGHT CAPACITY 100kg

PARTS:

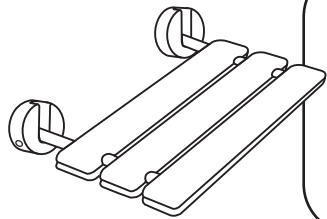

- 1 - SEAT ASSEMBLY
- 6 - FLAT HEAD SCREWS
- 6 - PLASTIC WALL PLUGS
- 2 - WALL BRACKETS
- 2 - WALL BRACKET COVERS
- 2 - MOUNTING PINS
- 2 - CAPS

SAFETY NOTICE:

The mounting brackets must be anchored to a solid structure ensuring a safe and secure installation. As a minimum standard, follow recommended installation below.

INSTALLATION (Refer to illustrations)

Drill 4 or 6 holes, whichever is required for installation using template provided. Secure wall brackets to the wall as shown below. Place wall bracket covers over brackets and secure seat assembly in place with the mounting pins. After assembly is completed fit caps into pin holes.

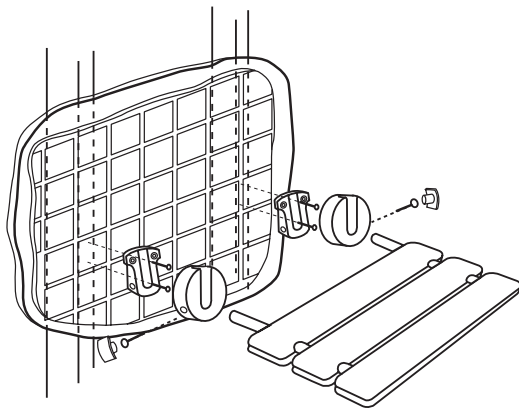

1. STUD WALL (mounting wood)

406mm on centre (use template provided) use (4) flat head screws provided for this installation. Screws should penetrate into the studs a minimum of 35mm. A 3mm dia masonry drill should be used to drill through tile and board for screw clearance hole.

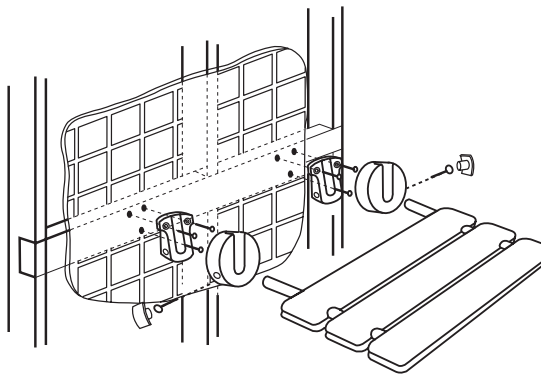

2. WOOD BATON (mounting wood)

406mm on centre (use template provided) Wood Baton to be 150mm x 50mm or equivalent and must be an adequate anchor base, secured into studs. Use (6) flat head screws provided for this installation. Screws should penetrate into the Baton a minimum of 35mm. A 3mm dia masonry drill should be used to drill through tile and board for screw clearance hole.

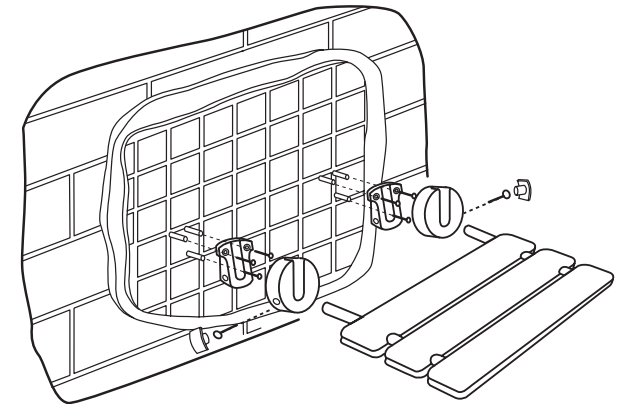

3. MOUNTING (Masonry, brick or block wall)

406mm on centre (use template provided). Install (6) plastic wall plugs provided for this installation. A 8mm diameter masonry drill should be used for this application.